

# BUILT IN ELECTRIC FIREPLACE INSTALLATION GUIDE

## MODEL NUMBERS:

**39EB500ARA**

**39EB500GRA**

**39EB500GRS**

## CONSUMER SAFETY INFORMATION

PLEASE READ THIS MANUAL BEFORE INSTALLING THIS APPLIANCE

### WARNING

IF THE INFORMATION IN THIS MANUAL IS NOT FOLLOWED,  
AN ELECTRIC SHOCK OR FIRE MAY RESULT CAUSING  
PROPERTY DAMAGE, PERSONAL INJURY OR LOSS OF LIFE.

DO NOT STORE OR USE GASOLINE OR OTHER FLAMMABLE  
VAPORS AND LIQUIDS IN THE VICINITY OF THIS  
OR ANY OTHER APPLIANCE.

Thank you and congratulations on your purchase of a Classic Flame fireplace. Please read the installation instructions before installing and operating this appliance.

**IMPORTANT:** Read all instructions and warnings carefully before starting installation. Failure to follow these instructions may result in a possible electric shock, fire hazard and/or injury and will void the warranty.

### For Customer Service:

E-Mail: [parts@twinstarhome.com](mailto:parts@twinstarhome.com)  
In English Call: 866-661-1218  
En Français Call: 866-374-9203  
En Español Call: 866-661-1218

Twin-Star International, Inc.  
Delray Beach, FL 33445  
U.S.A.

Made in China  
Printed in China

© 2011, Twin-Star International, Inc.

## LISTINGS AND CODE APPROVALS

THE BUILDERS BOX SERIES HAS BEEN TESTED AND APPROVED IN ACCORDANCE WITH THE CSA, No.220391, STANDARDS FOR FIXED AND LOCATION DEDICATED ELECTRIC ROOM HEATERS.

### MODEL SPECIFICATIONS

Model Number	Description	Voltage	Watts	Remote Control	Amps
39EB500ARA	39"Electric Box without any doors	120/208/240	1440/2100/2800	YES	12/10.1/11.7
39EB500GRA	39"Electric Box with glass front	120/208/240	1440/2100/2800	YES	12/10.1/11.7
39EB500GRS	39"Electric Box with double swing door	120/208/240	1440/2100/2800	YES	12/10.1/11.7

### !!! WARNING !!!

THE INSTALLATION OF THE FIREPLACE UNIT MUST COMPLY WITH THE APPLICABLE LOCAL AND/ OR NATIONAL ELECTRICAL CODES AND UTILITY REQUIREMENTS. THIS INSTALLATION SHOULD BE ENTRUSTED TO DULY QUALIFIED PERSONNEL WHERE REQUIRED BY LAW.

### STEP - BY - STEP INSTALLATION OVERVIEW

(please read all instructions before installation)

- 1) Rough in framing following the recommended dimensions. (see figure 1)
- 2) Allow at least 8" of service cable for connecting power supply wire to junction box on fireplace insert when installing before finishing wall. Allow up to 4 feet of service cable for connecting power supply wire to junction box on fireplace insert after finishing wall.
- 3) Remove the outer jacket and strip the individual conductors 1/2" from end.
- 4) Loosen the screw securing the junction box cover and remove the cover.
- 5) Place unit in position in the framed opening, level with shims if necessary and attach unit to frame using mounting flanges provided ( see Section 3).
- 6) Wire a dedicated, properly fused circuit with a 15 amp rating for the appropriate voltage (120, 208/240). (See table above)
- 7) Place all connections inside the junction box. Secure the junction box cover on the unit.  
When installing a cable clamp make sure it grips only the jacket of the service cable and thermostat wire.

### !POWER SELECTION WARNING!

This unit is factory wired for 120 volt power supply. If 120 volt operation is required, slide the voltage switch and reconfigure the wiring accordingly (see figure 2).

Wires L1, L2, N & G are attached to the rear of the junction box for easy access.



## Section 1: Framing

This fireplace is a zero clearance design. No combustibles can be placed on the top surface of the fireplace. Combustibles may be installed to the edge of the unit.

Four mounting flanges on the sides of the unit are provided to facilitate installation. Insulation and vapor barrier should be placed a minimum of 2 inches from the unit.

A	B	C	D	E	F	G	H	I	J	K	L	M
16.0"	39.0"	33"	32.7"	27.2"	38.7"	36.0"	22.0"	27.6"	15.3"	55.0"	38.9"	38.9"

Framing Specifications: Figure 1

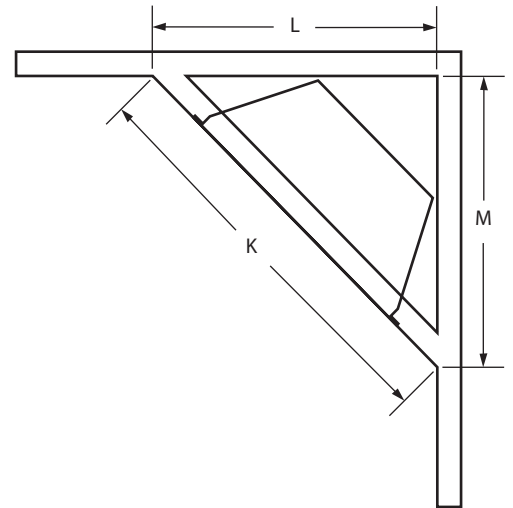
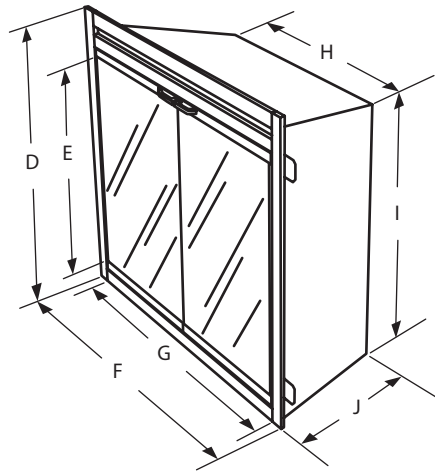
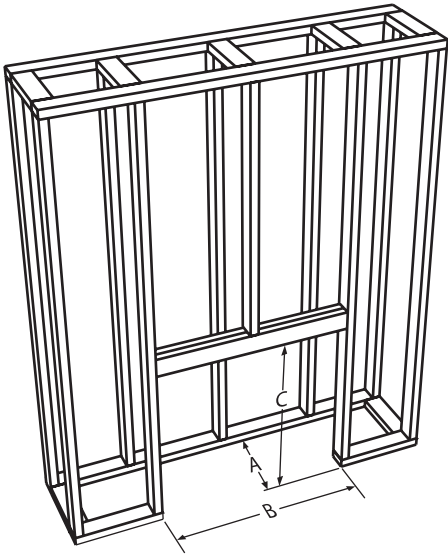

## Section 2: Recommended Power Supply Wire Specifications

**For 120 volt installations** use two conductor, non-metallic sheath cable with ground wire (3 wires total) for the incoming power supply on fireplace inserts. Use the appropriate wire to meet local and national electrical codes for rated power consumption.

**For 208/240 volt installations** use three conductor, non-metallic sheath cable with ground wire (4 wires total) for the incoming power supply on fireplace inserts. Use the appropriate wire to meet local and national electrical codes for rated power consumption.

Two conductor, non-metallic sheath cable with ground wire (3 wires total) is recommended for installation of a wall mounted thermostat for use on fireplace inserts.

### Recommended Wire and Fusing Requirements

Use appropriate wire to meet local and national electrical codes for rated power consumption. All wire gauges should be 12 gauge with a dedicated 15 amp breaker.

## Section 3: Voltage Selector Switch Location

### Important:

Ensure that the incoming power supply voltage matches the setting of the voltage selector switch!!!!!!

### Caution:

When changing the voltage selector switch from 240 volts to 120 volts ensure that the power supply is turned off.

The voltage selector switch is located behind the top brick panel on the right hand corner. When wiring the unit for 208/240 volts the voltage selector switch should be in the

230 volt position. (see figure 2)  
When wiring the unit for 120 volts the voltage selector switch should be in the 115 volt position. (see figure 2)

Voltage Selector Switch: Figure 2

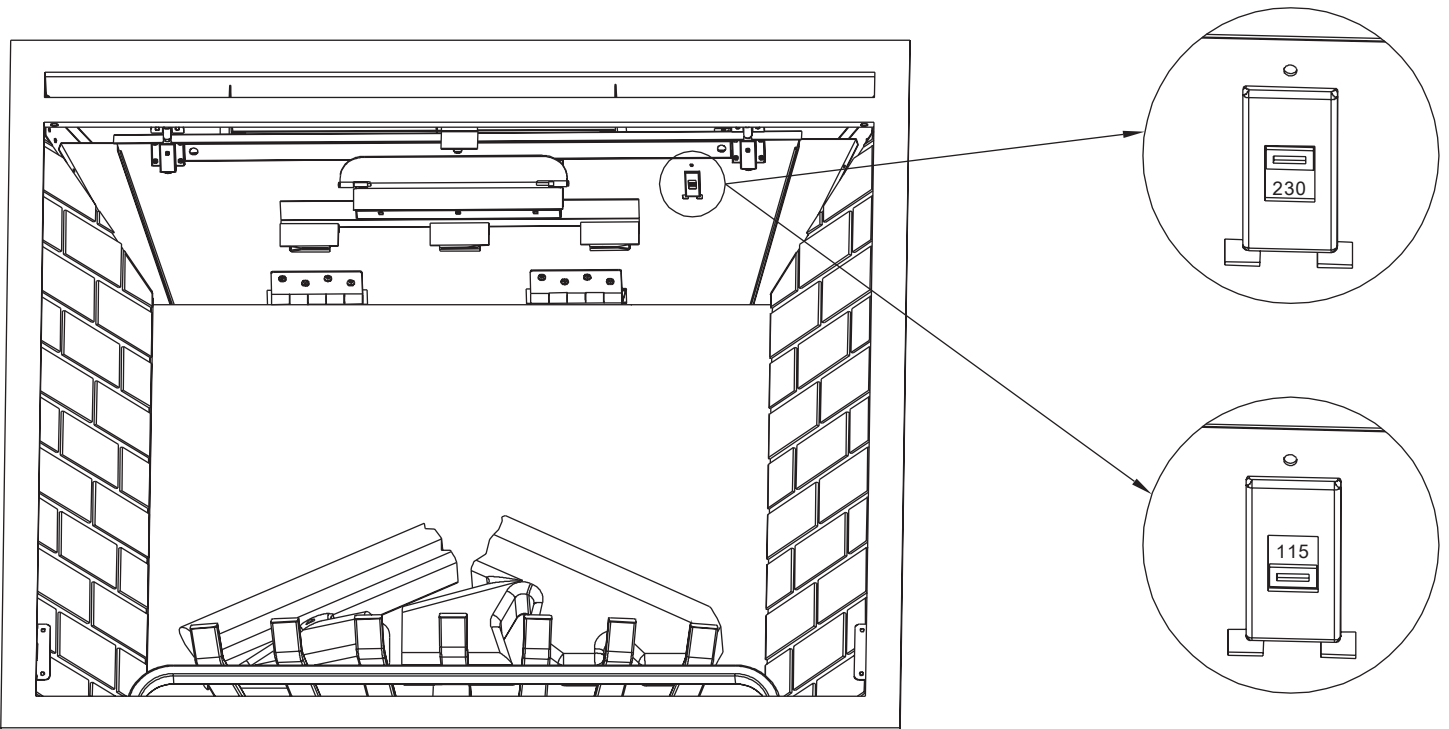

## Section 4: Mounting Flanges

There are two mounting flanges located on each side of the fireplace insert. In order to facilitate the transportation, we make the mounting flanges into flat status. Please bend the mounting flanges into 90° using suitable hardware before installation. (please see the figure 3)

Mounting Flange Location: Figure 3

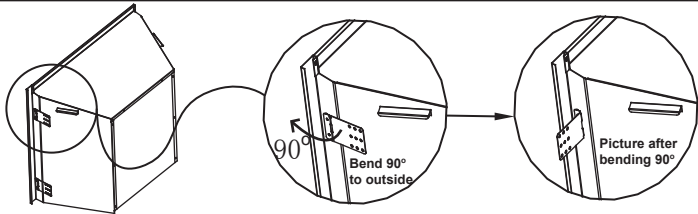
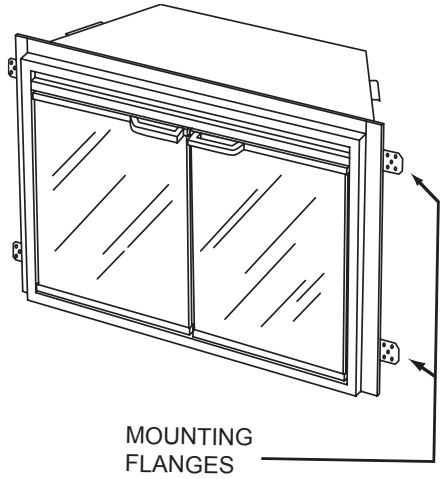

Wall and Mounting Flange: Figure 4

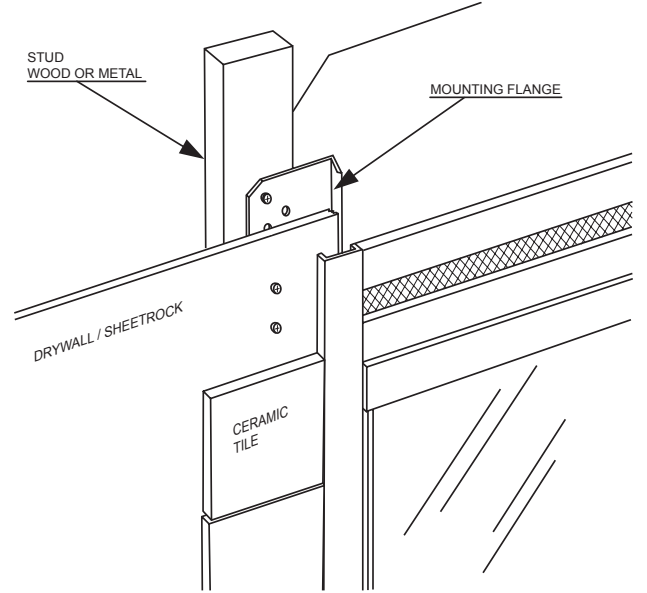

Mounting Tolerances - Top View: Figure 5

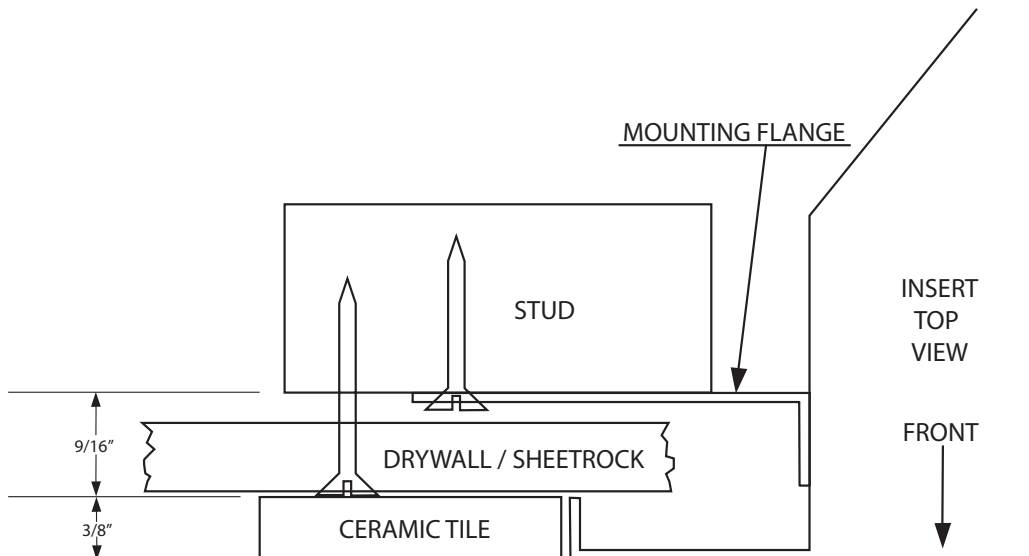

## Section 7: 120 Volt Installation Instructions

### Important

- The unit is factory configured for 120 volt operation.
- Use 2 conductor wire with ground (3 wires total) from the power supply (breaker panel) to the junction box on the unit.
- All wiring must be completed prior to installing the unit.
- Ensure that the voltage selector switch is in the proper position for the required supply voltage prior to connecting the unit to the power supply.

1. Locate voltage selector switch behind the top brick panel in the right hand corner.
2. Confirm the switch is set to 120 volt configuration ( 115 volt is printed on switch).
3. Loosen the screw securing the junction box cover and remove the cover.
4. Remove the knockouts (if necessary) or use a cable clamp (not provided).
5. Pull out the four wires marked L1, L2, N, and G.
6. Connect the black L1 wire from the unit to the black L1 from the power supply.
7. Connect the red L2 wire and the N wire from the unit to the N wire from the power supply.
8. Connect the green ground wire from the unit to the ground from the power supply.
9. Ensure that all connections are tight.
10. Insert all the wiring back into the unit and secure with a cable clamp.

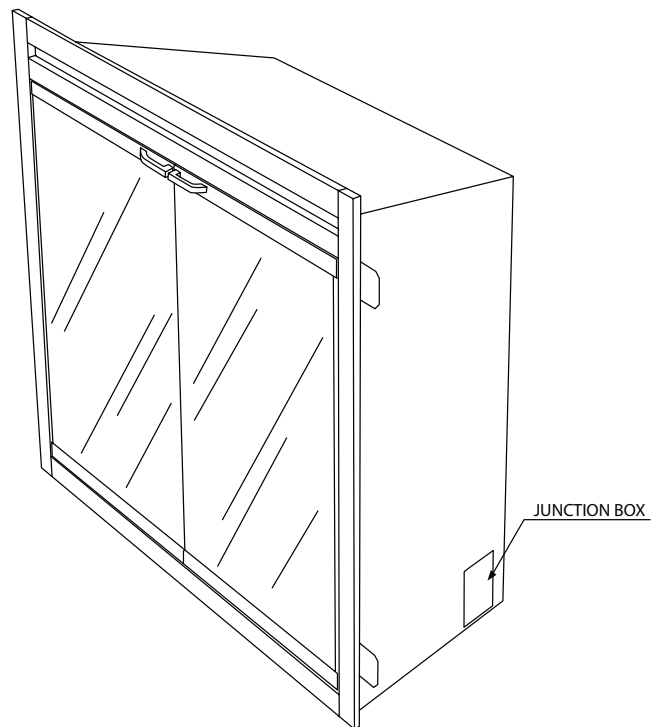

Junction Box Locator: Figure 6

**Figure 7: 120V Wire Connection Diagram**

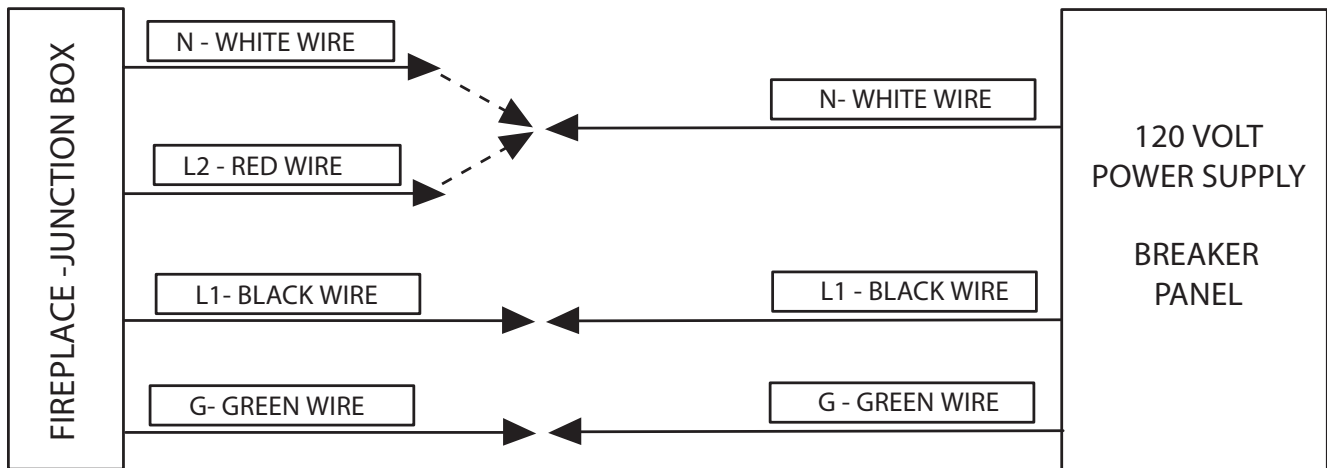
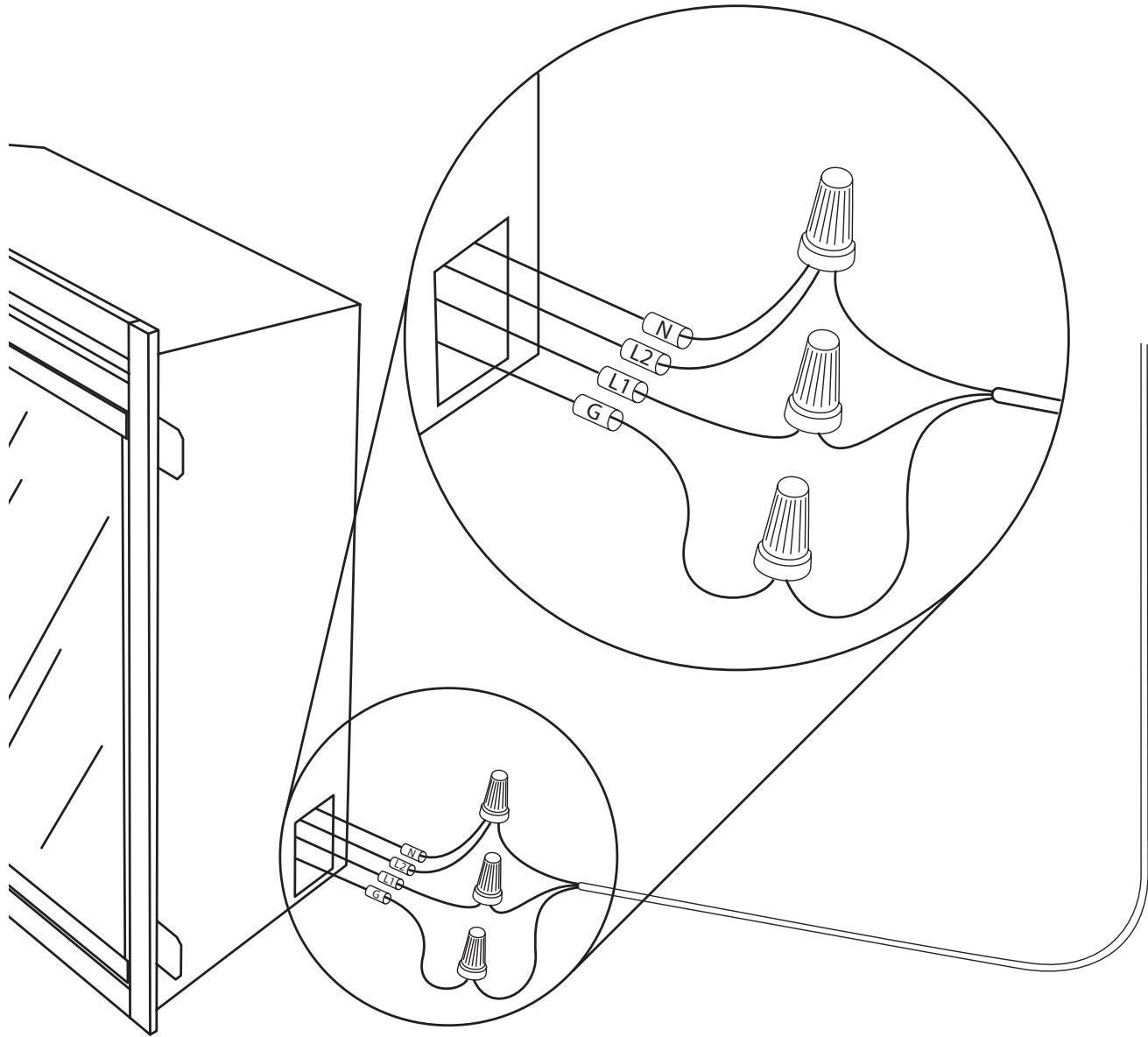

## Section 6: 240 Volt Installation Instructions

### Important

- The unit is factory configured for 120 volt operation. You must set the voltage selection switch to 240 volts (230 volt is printed on the switch).
- Use 3 conductor wire with ground (4 wires total) from the power supply (breaker panel) to the junction box on the unit.
- All wiring must be completed prior to installing the unit.
- Ensure that the voltage selector switch is in the proper position for the required supply voltage prior to connecting the unit to the power supply.

1. Locate voltage selector switch behind the top brick panel in the right hand corner. . (see figure 2 on page 3)
2. Confirm the switch is set to 240 volt configuration (230 volt is printed on switch).
3. Loosen the screw securing the junction box cover and remove the cover.
4. Remove the knockouts (if necessary) or use a cable clamp (not provided).
5. Pull out the four wires marked L1, L2, N, and G.
6. Connect the black L1 wire from the unit to the black L1 from the power supply.
7. Connect the red L2 wire from the unit to the red L2 from the power supply.
8. Connect the white N wire from the unit to the white N wire from the power supply.
9. Connect the green ground wire from the unit to the ground from the power supply.
10. Ensure that all connections are tight.
11. Insert all the wiring back into the unit and secure with a cable clamp.

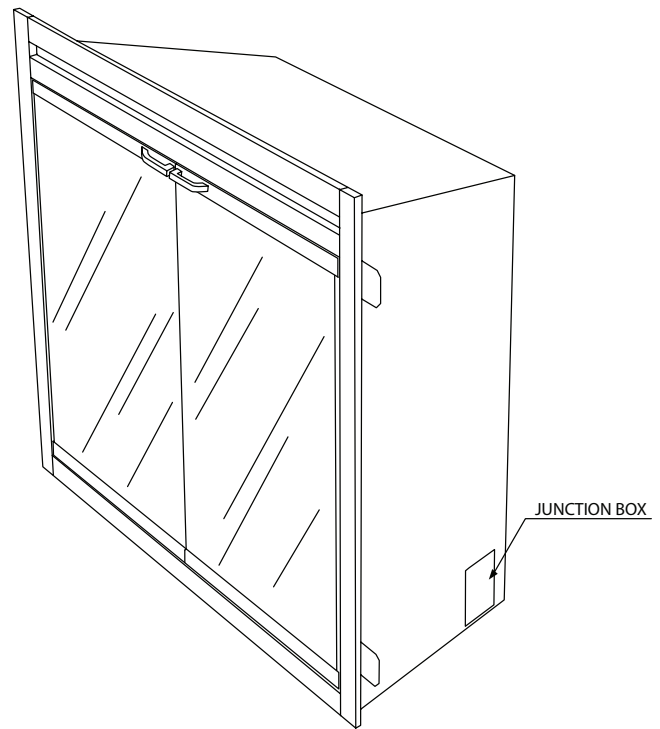

Junction Box Locator: Figure 8

**Figure 8: 240V Wire Connection Diagram**

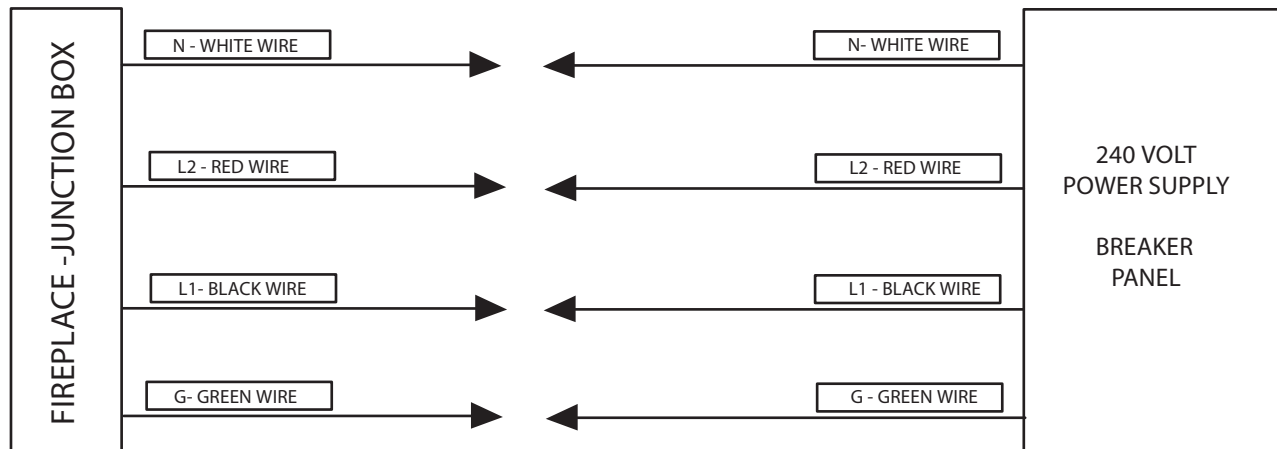
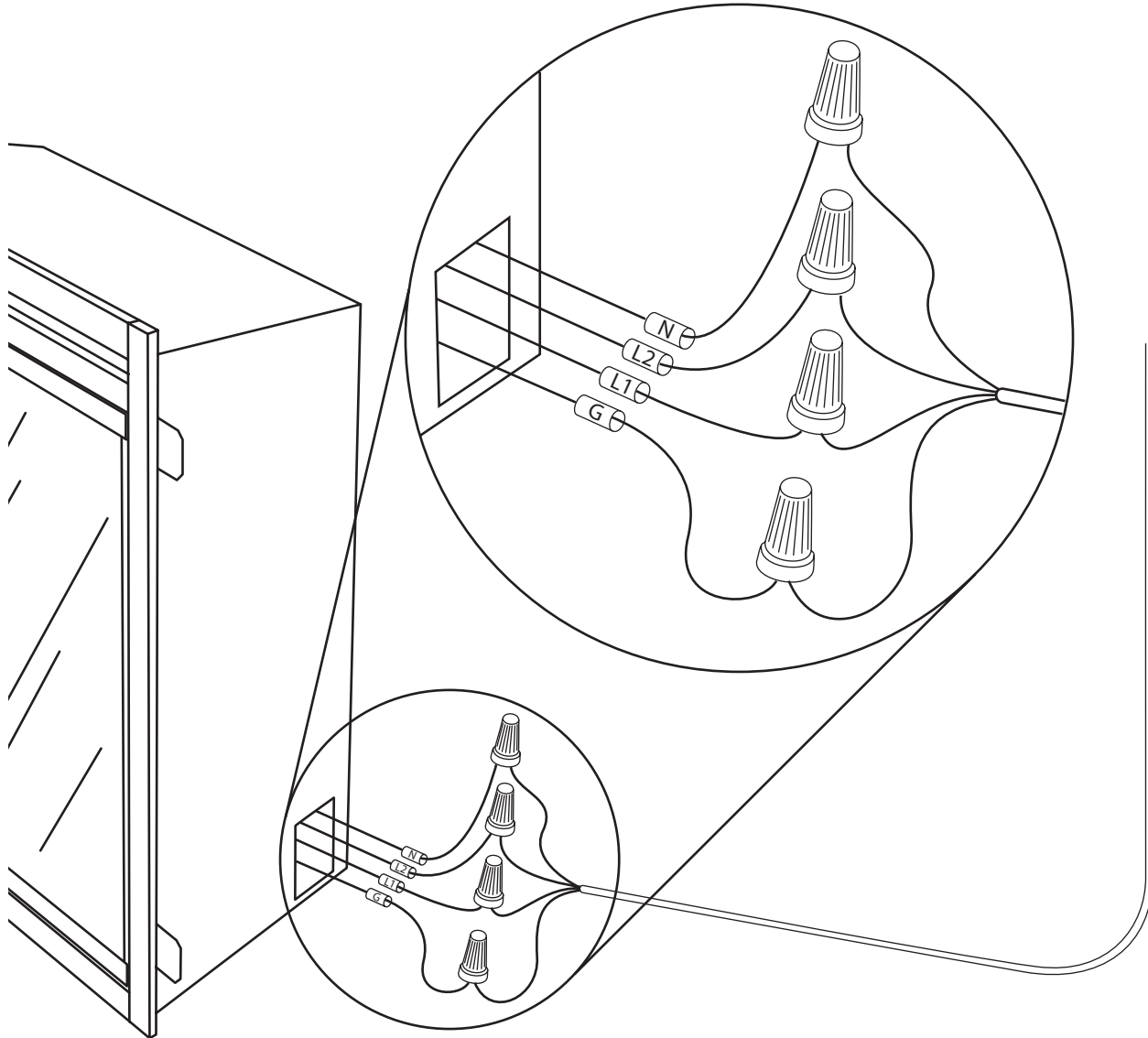

# Section 8: Wiring Schematic: Fireplace Wiring Diagram

